

# **VOLUME 4 – PROJECT SPECIFIC INFORMATION (FORMAL BID)**



## **9012 - Nut Tree Airport – Elevator Code Upgrade Project** 301 County Airport Road, Vacaville, CA 95866

### **BID SET** (03/23/23)

#### **TABLE OF CONTENTS**

##### **VOLUME 4 – PROJECT SPECIFIC INFORMATION**

01 11 00 SUMMARY OF WORK

DOCUMENTATION 1 – SCOPE

DOCUMENTATION 2 – SITE UTILIZATION PLAN

#### **PREPARED BY:**

GENERAL SERVICES DEPARTMENT  
Capital Projects Management Division  
675 Texas Street, Suite 2500, Fairfield, California



## SECTION 01 11 00 - SUMMARY OF WORK

### PART 1 - GENERAL

#### 1.01 WORK INCLUDED

- A. Work required to be performed by the Contractor:

Nut Tree Airport - Elevator Code Upgrade Project at  
301 County Airport Road, Vacaville, CA 95866

In conformity with the Scope, Drawings and Specifications, the Agreement Between Owner and Contractor, including the General and Supplementary Conditions and other Division 1 Specification Sections, hereinafter identified as applied to this Project; including furnishing all material, labor, tools, equipment and services necessary therefore and incidental thereto, complete and available for intended use.

#### 1.02 PROJECT DESCRIPTION and ADDITIONAL REQUIREMENT

- A. Project Description:

1. Contractor shall remove and replace existing with new door operator with Gal MOVFE 2500-HL Door Operator or SGV Wittur's Smart Global Vision Door Operator or equal.
2. Contractor shall remove and replace existing door guard with the GAL ScanGuard Light Curtain or Formula System-Safescreen Light Curtain or equal.
3. Contractor shall remove and replace existing with new controller. Controller shall be SMARTRISE HYDRAULIC CONTROLLER or LYKOS HYDRAULIC CONTROLLER or equal.
4. Contractor shall provide a new SMARTRISE SMARTCONNECT car-top run station or LYKOS car-top run station or equal.
5. Contractor shall remove and replace existing car positioning with new SMARTRISE SMARTPOSITIONING landing system or ALPHA landing system or equal.
6. Contractor shall replace all existing wiring and traveler cable with new wiring conductors and traveler cable
7. Contractor shall remove and replace existing car and hall fixture with new car and hall fixture. Buttons for the fixture shall be from SCS Elevator Products or equal.
8. Contractor shall retain existing fire alarm system and operations.
9. Contractor shall provide acceptance with the State of California Division of Industrial Relations / State of California Division of Occupational Safety and Health elevator unit.
10. Contractor shall provide system interface between elevator system and all relevant controls.
11. Contractor shall test and commission the elevator system.

#### 1.03 LOCATION OF SITE

- A. The site of the work is on County property located at 301 County Airport Road, Vacaville, CA 95866.



(Informal Bid)

#### 1.04 DRAWINGS AND SPECIFICATIONS

- A. The Specifications are those documents bound in the Project Manual and enumerated in the Table of Contents (Volumes 1-4), including General Conditions of the Contract for Construction, and Supplementary Conditions.
- B. For clarification: the documents released for bid are comprised of the drawings and specifications identified as "Issued for Bid" dated 03/23/23.

#### 1.05 PROJECTED CONSTRUCTION SCHEDULE

- A. Construction is scheduled for substantial completion within 120 calendar days from the Notice of Proceed, as stated in Section 00 41 00 – Bid Form and Section 00 52 00 – Agreement Construction Schedule (estimated dates): between Owner and Contractor.
- B. Estimated Critical Milestones of Construction Schedule:
  - .1 05-23-2023 Contract Execution Date Board Date
  - .2 05-25-2023 Issue Notice to Proceed
  - .3 05-29-2023 Construction (Mobilization) Start Date
  - .4 06-30-2023 Complete Submittal Review
  - .5 09-20-2023 Substantial Completion
  - .6 10-20-2023 Final Completion
  - .7 11-14-2023 Notice of Completion Filed Board Date
  - .8 11-14-2025 Guarantee/Warranty and Warranty Bond Expiration Date

#### 1.06 INTERRUPTION OF SERVICES

- A. Contractor shall make provisions to accomplish the work of this Contract without undue interference with the County and Court operations. Interruptions to services for the purpose of making or breaking connection shall be made only after consultation with the County a minimum of ten (10) working days in advance of connection break and shall be at such time and of such duration as may be directed. Contractor shall coordinate utility shutdowns for after-hours work.
- B. Work in other occupied spaces shall have minimal duration and to occur after hours to not interfere with operations.
- C. In addition, existing sewer, water, electrical, mechanical, and telephone/data lines disconnected for Work of this Contract shall not remain disconnected for more than 4 hours. If these utilities cannot be restored within the 4-hour period. Contractor shall provide temporary utility service to restore required utility at Contractor's expense. Electrical and fire sprinkler disruption needs to occur on non-public hours.

#### 1.08 SEQUENCE OF CONSTRUCTION OPERATIONS

- A. The Work will be conducted according to the Contractor's Construction Schedule accepted by the County.
- B. Before starting construction operations, Contractor shall confer with the County to review sequence of construction.
- C. The County desires to have the sequence of Work on-site in a manner to allow normal County and Court operations to continue and function for its intended purpose. The existing operations cannot be interrupted to cause impact on the day-to-day operations of the County and Court. The County does not want to dictate the 'means and methods' of the Contractor however there are operational



(Informal Bid)

issues that will need to be addressed.

- D. Contractor shall prepare schedules and include the sequencing of the Work as described on the Drawings and Specifications.
- E. Contractor shall coordinate erection of walls, steel framing, wall framing, wall panels, windows, partitions or other space enclosure with requirements of others for moving large pieces of equipment into building or outside the building or into room to be enclosed. Contractor shall consult with the Project Manager as to the necessity for deferring erection of such enclosures and shall deliver to the County a schedule of such deferments and reasons therefore. Cost of deferring construction shall be borne by Contractor.

#### 1.09 HOURS OF WORK

- A. The Contractor shall perform Work of this Contract on normal workdays and within the work hours of 7:00 a.m. to 5:00 p.m. The Contractor will be required to do any utility shutdowns.
- B. Work after hours and on Saturdays, Sundays and holidays is permitted as long as approval is received from the County at least 10 working days in advance.

#### 1.10 SITE CONDITIONS AND REQUIREMENTS

- A. Contractor shall keep drainage facilities, walks, and paved areas clean and free of mud and dirt, obstacles, etc. so that normal drainage and pedestrian and vehicular travel may be maintained.
- B. Contractor shall be responsible for restoring each area used back to the original condition.
- C. Do not use landscaped area(s) for work operations or storage unless area has been approved for use by the Project Manager. Contractor shall return area to original condition when work is completed.
- D. Contractor shall take pre-condition photos for the project conditions prior to start of the project of any existing damage to the building and submit to Solano County as part of the requirements of the contractors first pay application.

#### 1.11 WORK UNDER OTHER CONTRACTS

- A. Coordination with other contractors will be handled through the Project Manager. The Contractor will participate in all coordination meetings between contractors and will work cooperatively to accommodate the needs of other contractors without increasing the costs to the County. The Project Manager will set up said meetings and the number of meetings will be at the discretion of the Project Manager.

#### 1.12 CONTRACTOR USE OF PREMISES

- A. General: During the construction period the Contractor shall have full use of the designated Project area for construction operations, including use of the site. The Contractor's use of the premises is limited only by the County's right to perform construction operations with its own forces or to employ separate contractors on portions of the Project.
  - 1. Confine operations to areas in within Contract limits indicated including staging area and parking zone. Portions of the site beyond areas in which construction operations are indicated are not to be disturbed.
  - 2. Keep driveways and entrances serving the premises clear and available to the County and Court at all times. Do not use these areas for parking or





(Informal Bid)

storage of materials. Schedule deliveries to minimize space and time requirements for storage of materials and equipment on site.

3. Repair and replace damaged existing construction to remain such as curbs, parking lot paving, roadways, site vegetation and utilities.
4. Contractor to use East Elevator Room for Contractor's laydown/staging area. Contractors can park personal vehicles in designated contractor parking areas. See attached SITE UTILIZATION PLAN.

#### 1.13 MISCELLANEOUS PROVISIONS

##### A. Project Completion Requirements:

1. Before final acceptance, inspect, test and adjust performance of every system or facility of the Work to ensure that overall performance is in compliance with the contract documents.
2. No later than 1 year and 11 months after the Notice of Completion, and after County and Court use of the Project, return and again inspect, test and adjust the work. Measure performance relative to terms of the acceptance test performed at the end of the job and demonstrate and record compliance. See Section 00 72 00 – General Conditions of the Contract for Construction, for details and more information.
3. Submit a report of results to the County and Project Manager.
4. Instruct the County's operating personnel on operational requirements needed to maintain compliance.

PART 2 - PRODUCTS (Not Applicable)

PART 3 - EXECUTION (Not Applicable)

END OF SECTION 01 11 00

## **DOCUMENTATION 1 – SCOPE**

### SUMMARY SCOPE:

- Provide New Door Operator by GAL manufacturer or SGV Wittur’s manufacturer or equal
- Provide Control Package by Smartrise manufacturer or LYKOS manufacturer or equal
- Provide all new wiring and traveler cable
- Provide all new car and hall fixtures
- Retain existing FA (fire alarm) system and operations
- Provide elevator unit acceptance inspection with DIR (Division of Industrial Relations)

### DETAILED SCOPE:

- New Door Operator
  - Install a new linear door operator and infrared light ray door reopening device. These components are manufactured by GAL, and industry standard for passenger elevators (SEE EXHIBIT 01).
    - GAL MOVFE-2500-HL or SGV Wittur’s or equal-Linear door operator that opens and closes the car door. Included is a handheld parameter unit to be left on the job for elevator mechanics to adjust the doors in the future. This operator will be custom fitted to the existing elevator doors and car top.
    - Clutch, pickup rollers & interlocks are to be retained. Contractor will refurbish or replace components as required with like-for-like parts to bring their condition to like new.
    - Door tracks, hanger rollers, closers are to be retained. Contractor will refurbish or replace components as required with like-for-like parts to bring their condition to like-new.
    - Door for elevator shall be fitted with ScanGuard Light Curtain by GAL or Formula System-Safescreen Light Curtain or equal (SEE EXHIBIT 02).
- All Control Package
  - Install all new Smartrise Hydraulic Controller or Lykos Hydraulic Controller or equal — Microprocessor controller processes logic for inputs and outputs of the various elevator equipment to the required specifications. This unit is adjustable, programmable, and non-proprietary (SEE EXHIBIT 03).
    - Non-proprietary means that any qualified elevator mechanic has the ability to adjust, change or reprogram this unit with accessible documentation and tools. Documentation is publicly available through the Smartrise website.
    - Controller wiring diagrams in paper “laminated” and electronic format to be provided and left in the elevator machine room. Additional documentation for troubleshooting and testing is available for download through the Smartrise website.

## **DOCUMENTATION 1 – SCOPE**

- The existing emergency fire, operation control, and motion control will be retained.
- Install a Sprecher-Schuh soft starter for the pump motor. This device slowly ramps up voltage applied to the motor windings in order to induce inrush current and ease the electrical load on the motor and building power grid.
- Install a new car-top run station that allows service mechanics to operate and service the elevator from the top of the car (SEE EXHIBIT 04).
- Install a new Smart Positioning Landing System, a contactless dual infrared sensor & QR coded tape system. This locating device provides the controller with absolute positioning and speed feedback at all times (SEE EXHIBIT 05).
- All New Wiring
  - Contractor is to install new elevator components with all new wire. Contractor will use new wire for all new and existing elevator equipment connections. Elevator equipment is defined as all equipment downstream from the disconnect switch.
  - Wiring includes hoist-way wiring, traveler cable & supports, cab wiring, machine room equipment wiring, and all additional conduit & wire ways.
- New Fixtures
  - Contractor is to manufacture & install new hall and car fixtures to replace all existing elevator operating devices. Hall and car fixture buttons shall be SCS Elevator Products or equal (SEE EXHIBIT 06).
  - The car operating panel will include these fixtures:
    - DL-20 digital display & annunciation for floor position & travel direction
    - Emergency light system, with battery backup
    - Push-to-talk, hands-free emergency phone, with battery backup
    - Pushbutton activated emergency alarm bell, with battery backup
    - ADA-compliant pushbuttons, with required California braille for all floors and door controls
    - Newkey-switches with group security for maintenance and fire service functions
  - The new hall fixtures will be field measured and manufactured to match the existing dimensions. New hall stations will include the following:
    - Provisions for hookup with existing key card / fob security system.
    - New key switches with group security for maintenance and fire service functions.
  - Material for fixture plates is stainless steel with No. 4 brushed finish. All applied-plate style fixtures are made of robust, heavy gauge stainless steel plate. Fixtures use hidden or vandal resistant fasteners where possible.
  - Retain exiting cardkey access and revise existing cardkey pads.
  - Provide new LED light fixture.

**DOCUMENTATION 1 – SCOPE**

- Retain Existing Fire Alarm System
  - The existing fire alarm devices and controls will be retained. Contractor will trace existing signals and integrate with the new controller. All existing fire alarm key- switches, indicators for the elevator will be replaced with new components.
  - Fire alarm initiating devices are to be provided by Solano County. The County is to coordinate with the County Fire Alarm company to pretest fire alarm system with the contractor prior to the final acceptance inspection. Solano County is to coordinate again for the County Fire Alarm company to be present at the date and time of the acceptance inspection.
  - The contractor shall include one day field labor to pre-test the fire alarm system in coordination with the fire alarm contractor. Additional field labor to help troubleshooting fire alarm.
  
- DIR (Division of Industrial Relations) Elevator Unit Acceptance Inspection
  - Contractor is to submit notification to the state for the proposed alterations. Contractor to coordinate with the State upon completion for request and scheduling of the final acceptance inspection.
  - This includes one day field labor for elevator inspection by the DIR/DOSH (Division of Occupational Safety and Health) Elevator Unit. Fire alarm & electrical contractors are required to attend elevator’ inspection per date & time provided by the State.
  - Contractor to include inspection fees charged by the DIR/DOSH elevator unit for the acceptance inspection are included on this project.

**ELEVATOR EXISTING CONDITION:**

- Quantity                    One Elevator
- Manufacturer            Dream Ride Elevator
- Machine                    Hydro-Electric
- Class                        Passenger Elevator
- Capacity                    2,500 Pounds
- Speed                        150 feet per minute
- Travel                        15 feet
- Stops                        Two-Front Only
- Entrance                    36 inches x 84 inches
- Door Type                 Side Parting – Single Speed
- Power                        240 Volts – 3 Phase-100 Amp

**DOCUMENTATION 1 – SCOPE**

# EXHIBIT 01

DOOR OPERATOR

GAL MOVFE-2500-HL DOOR  
OPERATOR

or

SGV-WITTUR'S SMART GLOBAL  
VISION DOOR OPERATOR

Or

EQUAL

REPLACE EXISTING DOOR OPERATOR WITH MOVFE  
2500-HL LINEAR DOOR OPERATOR  
OR  
SGV-WITTUR'S SMART GLOBAL VISION  
DOOR OPERATOR  
OR  
EQUAL

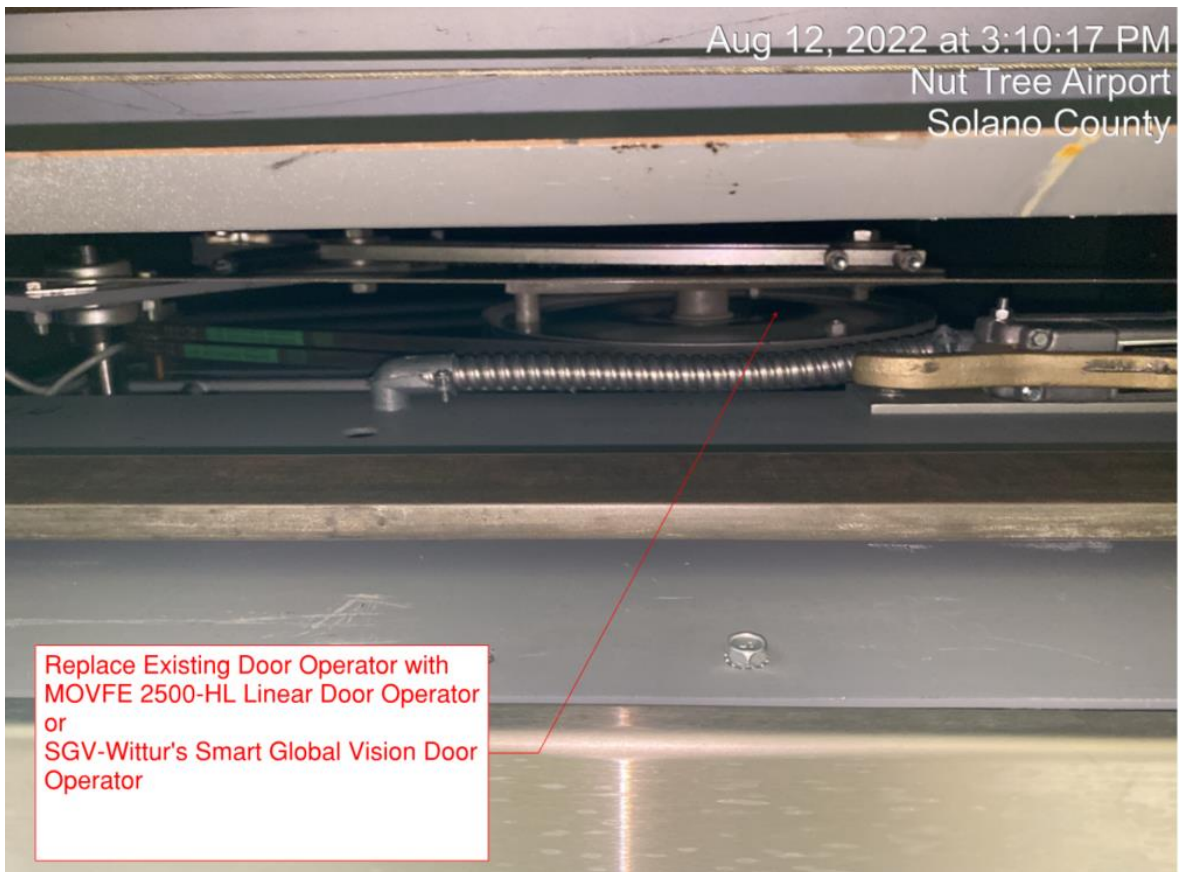

**GAL  
MOVFE-2500-HL**

**DOOR  
OPERATOR**





## A ROBUST, HEAVY-DUTY LINEAR DOOR OPERATOR

Designed to be highly adaptable, quiet, reliable, and provide added muscle to handle any job



### BENEFITS

- 'Learns' door width and optimizes control of elevator doors
- 'Plug-and-Play' infrared detector edges (NPN and PNP)
- Auto-fall back to reduce power mode if sensors or encoder fail
- Serial communication option
- Universal inputs and outputs
- Over-torque and over-speed detections
- Keypad also available



A JMTJGE Company



A VANTAGE Company

6500 Gottardo Court  
Mississauga, ON L5T 2A2  
Ph: 416.747.7967  
Fax: 416.747.9035  
info@galcanada.com  
www.galcanada.com

50 E. 153rd St.  
Bronx, NY 10451-2104  
Ph: 718.292.9000  
Fax: 718.292.2034  
info@gal.com  
www.gal.com

REGIONAL SERVICE CENTERS  
Miami — 877.241.9354  
Chicago — 877.300.5830  
Los Angeles — 877.300.5816  
New York — 347.226.4555  
Toronto — 888.425.2262

**MOVFE 2500-HL** Linear Door Operator

**FEATURES**

- Double-feedback closed-loop system constantly monitors distance and velocity
- CSA Certified, B44.1/ASME-A17.5
- Complies with CE and IEEE safety standards: EN61000-4-2-6, EN61000-4-8, IEEE STD C62- 45-1992 (EMC conformity report available)
- Non-Contact hall-effect sensors
- LEDs on main board indicate critical function status
- Pluggable input modules, output relays, and connectors
- Toggle switches provided for manual operation, diagnostics, and operational verification, regardless of condition of control wiring to elevator controller
- Keypad programmer with LCD display to adjust, monitor, copy, and upload parameter sets and learn door width distance
- Over-torque and over-speed detection and restriction limits are defined for easy adjustment and code compliance
- NPN and PNP linear curtains connected directly to Door Operator (Plug-and-Play)
- CAN (Controlled Area Network) and other protocols can be used for serial communication
- Handles up to 2,000 lbs total door weight

**ELECTRICAL SPECIFICATIONS**

POWER SUPPLY	MOTOR	INPUTS	OUTPUTS
230 VAC / 115 VAC	1/2 HP AC motor (accommodates most door loads, friction and wind pressures)	Universal inputs (accept control signals in form of dry contacts or signal voltages from 24V to 230V, AC or DC)	10A, 230 VAC



# SGV - WITTUR'S SMART GLOBAL VISION DOOR OPERATOR



*safety* **in** *motion*™

wittur.com





## SGV - Wittur's Smart Global Vision Door

DOOR EQUIPMENT FOR MID AND HEAVY DUTY  
NEW INSTALLATION AND MODERNIZATION



North America - A17.1/B44 Code Compliant

safety *in* motion™

[www.wittur.com](http://www.wittur.com)



A high reliable robust design, based on proven and easy-to-install components

# SGV - Wittur's Smart Global Vision Door



## 1 Modular approach for a wide range of applications

- SGV door system can be used in a variety of applications, from SGV6 medium duty doors for elevators in residential buildings up to SGV2 doors for high duty elevators in office buildings and hotels.
- SGV2 and SGV6 share the same layout: you can install SGV2 enhanced performance doors on the high used floors and apply SGV6 on the other floors.
- SGV is available as a complete entrance with a range of options for frame (16ga, 14ga), sill assembly, and panels (single skin, double skin, cladded, framed glass) in several distinctive finishes.
- SGV is also available as a modernization kit for most OEM's; MOD kits include adjustable car door operator brackets, door panel adapters to interface with existing door panels, and the clutch with integrated car door interlock.
- GAL, MAC, DOVER, WESTINGHOUSE, OTIS kits are available for interfacing to existing landing door locks, plus more than 70 special engineered job specific car door locks.



## 2 High performance

- SGV doors combine robust design and high performance with eco-efficient drives.
- SGV MIDI or SUPRA linear door operators achieve their high performance, high speed operation through a powerful permanent magnet synchronous motor.
- SGV operators share the same mechanical components as the corresponding landing doors.
- Customized CAN interface available.
- Discrete and serial (CAN bus) communication interfaces available.



## 3 Labor saving installation and maintenance

- Easy access and control of operator from the entrance or from the cab roof.
- Low space requirement leaves rooftop free of equipment
- Simple maintenance with few moving parts
- Dependable electronics with a multitude of options
- Heavy duty clutch CSA certified car door interlock eliminates the need for additional restrictors
- Large PU Coated  $\varnothing$  3 3/4" (94mm) hanger Rollers for reliable and silent operation





**4 Compliant to North American Codes**

- SGV is compliant with ASME A17.1/B44 and certified by CSA NRTL/C, including certified car door interlock.
- SGV doors are also available in fire resistant execution certified according to UL 10B 1-1/2H, door heights up to 120".

Door Drive Parameters		
	Midi+	Supra
Motor characteristics	3 phase Permanent Magnet Synchron Motor	3 phase Permanent Magnet Synchron Motor
Drive	V3F-Converter (vector control)	V3F-Converter (vector control)
Average Power Consumption	92 W	170 W
Max Momentary Power Consumption	475 W	900 W
Power Supply	Univ. 115-230 V ±20% 50/60 Hz	Univ. 115-230 V ±20% 50/60 Hz
Max. Speed	2 ft/s (0.6 m/s)	3.3 ft/s (1.0 m/s)
Max. Panel Weight by Railing	SGV6 = 140 lb (65 kg)	SGV2 = 275 lb (125 kg)
Protection Class	IP20	IP20
Storage Temperature	-45 ... +70 °C	-45 ... +70 °C
Operating Ambient Temperature	-20 ... +50 °C	-20 ... +50 °C
Humidity Range	98% max. 40 °C	98% max. 40 °C
Regulations and Codes	EN 81, ASME A17.5, CAN/CSA-B441	
Electromagnetic compatibility	Immunity and emission protection acc. EN 12015/16	
Max. Movable Masses (car and landing door panels)	595 lbs / 270 kg	1320 lbs / 600 kg
Noise Level (door operator)	Average 55 dB, max. 60 dB	Average 50 dB, max. 55 dB
Estimated Lifetime	More than 3 million cycles	More than 5 million cycles

**Production range**

Door Type <sup>1</sup>	Illustration	OOI (inch step)	
		MIN	MAX
1S right <sup>2</sup>		32"	48"
1S left <sup>2</sup>			
2C left <sup>2</sup>		36"	60"
2C right <sup>2</sup>			
2T right <sup>2</sup>		30"	72"
2T left <sup>2</sup>			
4C left <sup>2</sup>		48"	118"
4C right <sup>2</sup>			

<sup>1</sup> Contact Wittur representative for non-stock sizes. <sup>2</sup> Opening to the left / right - seen from the hall.



# EXHIBIT 02

## LIGHT CURTAIN

ScanGUARD  
or  
FORMULA SYSTEM -SAFESCREEN  
or  
EQUAL

**REPLACE EXISTING DOOR GUARD WITH SCANGUARD  
LIGHT CURTAIN**  
or  
**FORMULA SYSTEM SAFESCREEN LIGHT CURTAIN**



# ScanGUARD LIGHT CURTAIN



**BENEFITS**

- Proven design: Durable, vandal-resistant, 24-month warranty
- Easy installation: Directly connects to all 'MOVFR' and 'MOVFE' door operators  
Installs on side and center door opening configurations



**FEATURES**

- 63 non-parallel beam paths (crossbeams) that function even in the most extreme sunlight conditions
- Detection range: 0-6 ft. (0-1.83 in)

- All mounting hardware provided
- **Economically priced. Excellent choice for new or modernization projects.**

SPECIFICATIONS
- Seven feet (2.14 m) long
- Power: 24V DC
- Slim 1.18 x 0.81 in (30x20mm) aluminum alloy profile
- Comes complete with all mounting hardware, clips, cables (Super Flex), 9/64 in. (3.6mm) drill bit and full installation instructions



A JNTJGE Company

50 E. 153rd St.  
Bronx, NY 10451-2104  
Ph: 718.292.9000  
Fax: 718.292.2034  
info@gal.com  
www.gal.com

**REGIONAL SERVICE CENTERS**

- Miami— 877.241.9354
- Chicago— 877.300.5830
- Los Angeles — 877.300.5816
- New York — 347.226.4555
- Toronto — 888.425.2262

# FORMULA SYSTEMS SAFESCREEN LIGHT CURTAIN

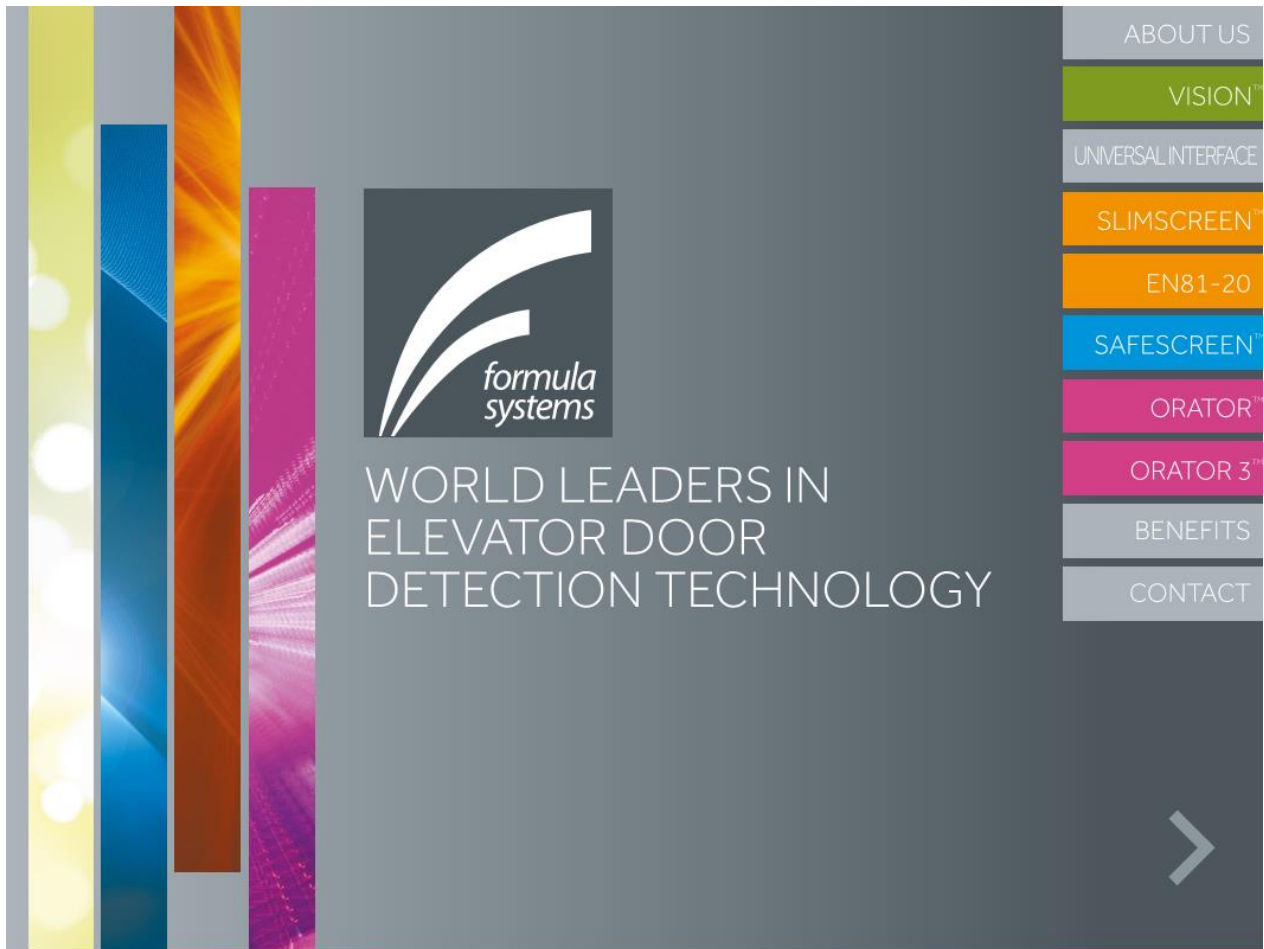



Designed for the North American market.  
 Capable of wiring directly into suitable door controllers or Formula's Universal Interface.

ABOUT US

VISION™

UNIVERSAL INTERFACE

SLIMSCREEN™

EN81-20

SAFESCREEN™

ORATOR™

ORATOR 3™

BENEFITS

CONTACT

PRODUCT VERSIONS

MODEL	VERSION	DIMENSIONS (MM)			RANGE (M)		MOUNTING BEAMS		
		W	D	H	MIN	MAX	DOOR TRACK	QTY	TOP
0524	Freight	30	20	2136	0	4.0	*	24	1788
0515	Standard	30	20	813	0	1.8	*	15	460
0547	Standard	30	20	2136	0	1.8	*	47	1788
0547	Long Range	30	20	2136	0	5.0	*	47	1788
0647	Standard	30	20	2000	0	1.5	*	47	1788

**PRODUCT STANDARD CHARACTERISTICS (UNLESS OTHERWISE NOTED):**

Response Time: <100ms	Light Immunity: >100,000 lux
Output: NPN	Indicators (LED): Red obstruction
Ingress Protection: IP54	Temperature: Ambient -20°C to +70°C, Storage -40°C to +80°C
Operating Voltage: 24v (18 - 30)	Material: Al. Alloy casing, plastic lens cover
Current Consumption: 100mA (Typical)	Approvals & Certification: cULus, CE







**formula**  
SAFESCREEN™

The latest version of our North American design, featuring 47 diagonal infra-red (IR) beams in an aluminium housing 30mm wide x 20mm (1.2" x 0.8"). As with the FCU35, the FCU47 is capable of wiring directly into suitable door controllers, or the FPS 0274 Universal Interface.

The FCU47 is backward compatible with any Formula Systems power supply allowing companies to upgrade old technology at a fraction of the price of a new system.

**DOWNLOADS**  
 Visit [www.formula-systems.com](http://www.formula-systems.com) to download detailed technical specifications of each product.

ABOUT US

VISION™

UNIVERSAL INTERFACE

SLIMSCREEN™

EN81-20

SAFESCREEN™

ORATOR™

ORATOR 3™

BENEFITS

CONTACT

**DIAGRAM & DIMENSIONS**

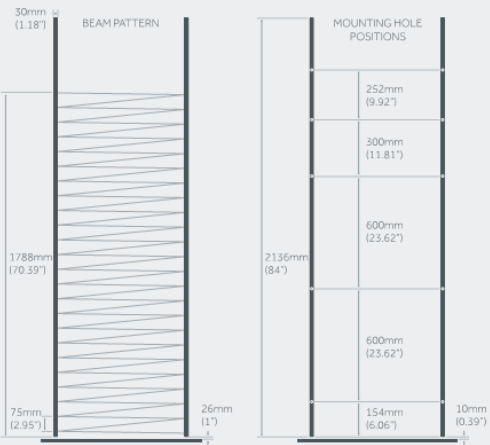

BEAM PATTERN		MOUNTING HOLE POSITIONS	
30mm (1.18")	1788mm (70.39")	252mm (9.92")	2136mm (84")
75mm (2.95")	26mm (1")	300mm (11.81")	600mm (23.62")
		600mm (23.62")	600mm (23.62")
		154mm (6.06")	10mm (0.39")



**MODEL: FCU<sup>47</sup> SAFESCREEN**

**CODE: FCU 0547\*\*01/02      \*\*CUSTOMER SPECIFIC**

PRODUCT SPECIFICATION

Item	Detail	Additional comments
Number of beams	47 non-focused beams	Infra-red
Number of Sensors	24	See drawing outline
Sensor Spacing	2.95" (75mm)	See drawing outline
Distance between beams at pinch point (doors closed)	1.48" (37.5mm)	See drawing outline
Scan Type	Interleaved	
Response Time	10 to 100 milliseconds	Relates to point of detection in scan cycle
Range of detection	6' Door mounted (1800mm) 16' Door mounted (5000mm)	Standard Range product FCU 0547**01 Long range product FCU 0547**02
Light Immunity	50 000 lux	Visible light
Angular displacement	10°	
Positional mounting tolerance	+/- 0.7" (18mm) vertically +/- 0.2" (5mm) side by side	Doors closed, units touching
Operating voltage	24 volts	16 volts min 30 volts max
Current consumption	<100 mA RMS	Total of both units
Control unit	Not required	Optional Interface (FPS 0270 or FPS 0271)
Environmental protection	IP54	Conformal coating to PCB's
Operating temperature range	-20°C to +70°C	Ambient environment
Storage temperature range	-40°C to +80°C	
Unit size	1.18"x0.8"x7" (30x20x2136mm)	
Mounting	Five screw positions	See drawing outline
Indicators	Supply present: System fault / beams obstructed:	Green LED Red LED
Cable supplied	Two x 13' (4m) approx of 3 core cable	Connects to product via short fixed lead
Case material	Aluminium alloy	Finished Black
Cover (filter)	Infra-red transparent plastic	Snap-on fixing
Installation kit	Instructions - 1 off Spacer Block - 1 off Cable Clips - 6 off Nytie - 3 off Screws 8-32unc x 1/2" - 20 off Washers - 20 off Washer Spring - 20 off Mounting Brackets - 2 off Screws M5.0 x 10mm - 10 off Washers M5.0 - 10 off Cable retainer - 2 off Screwdriver - 1 off Drill Bit - 1 off	Hex. Flanged Head (self Tapping)  Use with Mounting Bracket Use with Mounting Bracket Optional Optional Optional
SYSTEM APPROVALS	UL, cUL, CE (EMC)	EN12015, EN12016.

SPEC 0119 1/2 ISSUE 08 06-OCT-10

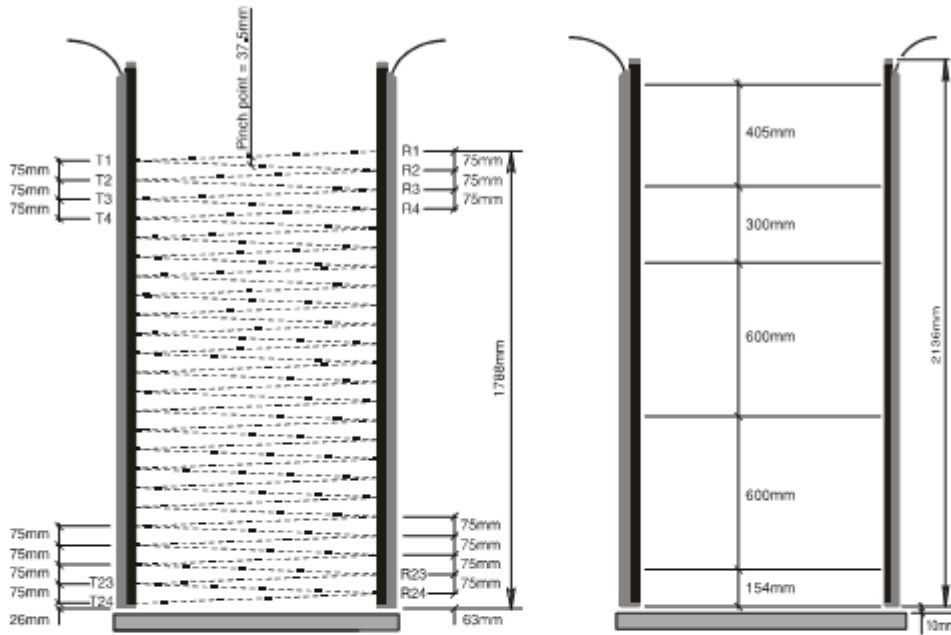

PRODUCT OUTLINE DRAWING

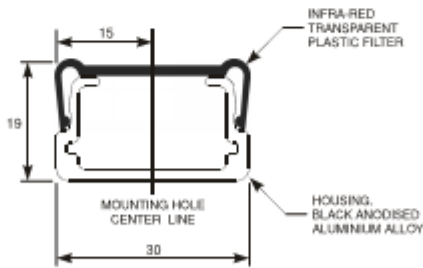

**FCU 0547 Series**  
 (Nominal dimension shown)

SPEC 0119 2/2 ISSUE 08 06-OCT-10

### FCU<sup>47</sup> SAFESCREEN SYSTEM INSTALLATION

**PACKING LIST FDS 0547**

**Product:**

- 1 - Safescreen Receiver x 1
- 2 - Safescreen Transmitter x 1
- 3 - Interface Unit (See Reverse) x 1
- 4 - Cable Assembly x 2
- 5 - Mounting Bracket x 2
- 6 - Installation Guide x 1

**Accessories:**

- 7 - M5 x 10mm Screw (standard) x 10
- 8 - M5 Washer Plain x 10
- 9 - M5 Washer Shakeproof x 10
- 10 - M4 x 20mm Screw (thread forming) x 24
- 11 - M4 Washer Plain (large diameter) x 24
- 12 - M4 Washer Shakeproof x 24
- 13 - Drill Bit 3.6mm x 1
- 14 - #10 x 13mm Screw (self drill) x 14
- 15 - Spacer Block x 1
- 16 - Cable Clips x 6
- 17 - Nylon x 8
- 18 - Self adhesive pads x 4
- 19 - Cable retainer x 2

#### Side Opening

#### Center Opening

16, 10, 11, 12, 13

3/8" (10mm) Spacer

1/8" (3 mm)

1/8" (3 mm)

1/8" (3 mm)

LEAF0130 Iss 04 07-JUN-04

## FCU<sup>47</sup> SAFESCREEN SYSTEM INSTALLATION

### INDICATOR LOCATIONS

### FINAL CHECK & TROUBLESHOOTING

INTERFACE UNIT - FPS 0271		
Indicator	Status	Action
Green	On - Supply OK	Check AC (DC) Supply
	Off - No Supply	
Red	Off - No Obstruction (relay energised)	Remove obstruction
	On - Obstruction (beam broken)	

SAFESCREEN TRANSMITTER		
Indicator	Status	Action
Green	On - Supply OK	Check AC (DC) Supply & Cables for damage
	Off - No Supply	

SAFESCREEN RECEIVER		
Indicator	Status	Action
Green	On - Supply OK	Check AC (DC) Supply & Cables for damage
	Off - No Supply	
Red	Off - No Obstruction	Remove obstruction
	On - Obstruction (beam broken) Flash - Single Beam Override Active	

### INTERFACE UNIT - DETAILS

#### INTERFACE UNIT - FPS 0271

#### INTERFACE UNIT - FPS 0270

#### FIELD WIRING

Cable insulation to be rated 60°C minimum. Copper conductors must be used.  $>60^{\circ}\text{C}$  Cu

Nominal tightening torque value 0.45Nm 0.45Nm

Route cable through the holes provided adjacent to the point of connection.

### INTERFACE UNIT - ADDITIONAL INFORMATION

#### FPS 0271 - BUZZER / NUDGING FEATURES

The FPS 0271 buzzer/nudging power supply offers a variety of features to facilitate elevator door control set-up during continuous beam interruption.

As with our standard power supply, the FPS 0271 features a simple relay that activates whenever beam paths are blocked.

In addition to the "standard" relay, the FPS 0271 includes a second relay, that will activate after beam paths have been continuously blocked for a pre-determined period of time. This "time-out period" can be determined by the installer during set-up by way of a variable potentiometer mounted on the power supply circuit board.

As elevator controllers have become more intelligent over time, Formula have included a relay configuration option that may be invoked through "Switch #3".

For older elevator systems, door speed/power are typically a door-operator controlled function. The door controller simply controls the instructions to open or close doors. Therefore, if a constant obstruction is detected, the "standard" relay will activate as normal, and remains activated until the "time-out" relay switches.

On older elevators, the "time-out" relay would switch in a resistor to effectively reduce the motor power to slow-down the closing speed of the doors. However, with the beam-path obstruction still present, the "standard" relay would still be activated, therefore the controller would still not know that the doors can now be instructed to close.

Switch #3 resolves this conflict. If switch #3 is in the "on" position, as soon as the "time-out" relay activates, the "standard" relay immediately reverts to a "no obstruction" state, even though an obstacle remains. Therefore, the "time-out" relay switches in the door speed resistor on the operator, and at the same time the door controller sees an "all clear" from the "standard" relay, thereby allowing the doors to be instructed to close.

Leaving switch #3 in the "off" position may be a requirement for more sophisticated controllers that can invoke slow-speed closing from the "time-out" relay and can ignore the "standard" relay signal.

In order to see this feature in operation, let a power supply time-out (this can be done bench-mounted without edges connected), and turn switch #3 on and off. This should activate and de-activate the "standard" relay.

EVENT SEQUENCE - BUZZER / NUDGING OPERATION			
Event	Standard Relay (Switch 3 OFF)	Standard Relay (Switch 3 ON)	Time-out Relay
No obstruction	Dormant	Dormant	Dormant
Obstruction before time-out period	Active	Active	Dormant
Obstruction after time-out period	Active	Dormant	Active

**Contacts:**

Formula online: <http://www.formula-systems.com>

Customer Care: North America: 1-866 952 9200 (toll free)  
 Others Countries: +44 (0)1865 882442

# EXHIBIT 03

## ELEVATOR CONTROLLER

SMARTRISE HYDRAULIC CONTROLLER

or

LYKOS HYDRAULIC CONTROLLER

or

EQUAL

**REPLACE EXISTING ELEVATOR CONTROLLER WITH  
SMARTRISE HYDRAULIC CONTROLLER  
or  
LYKOS HYDRAULIC CONTROLLER**

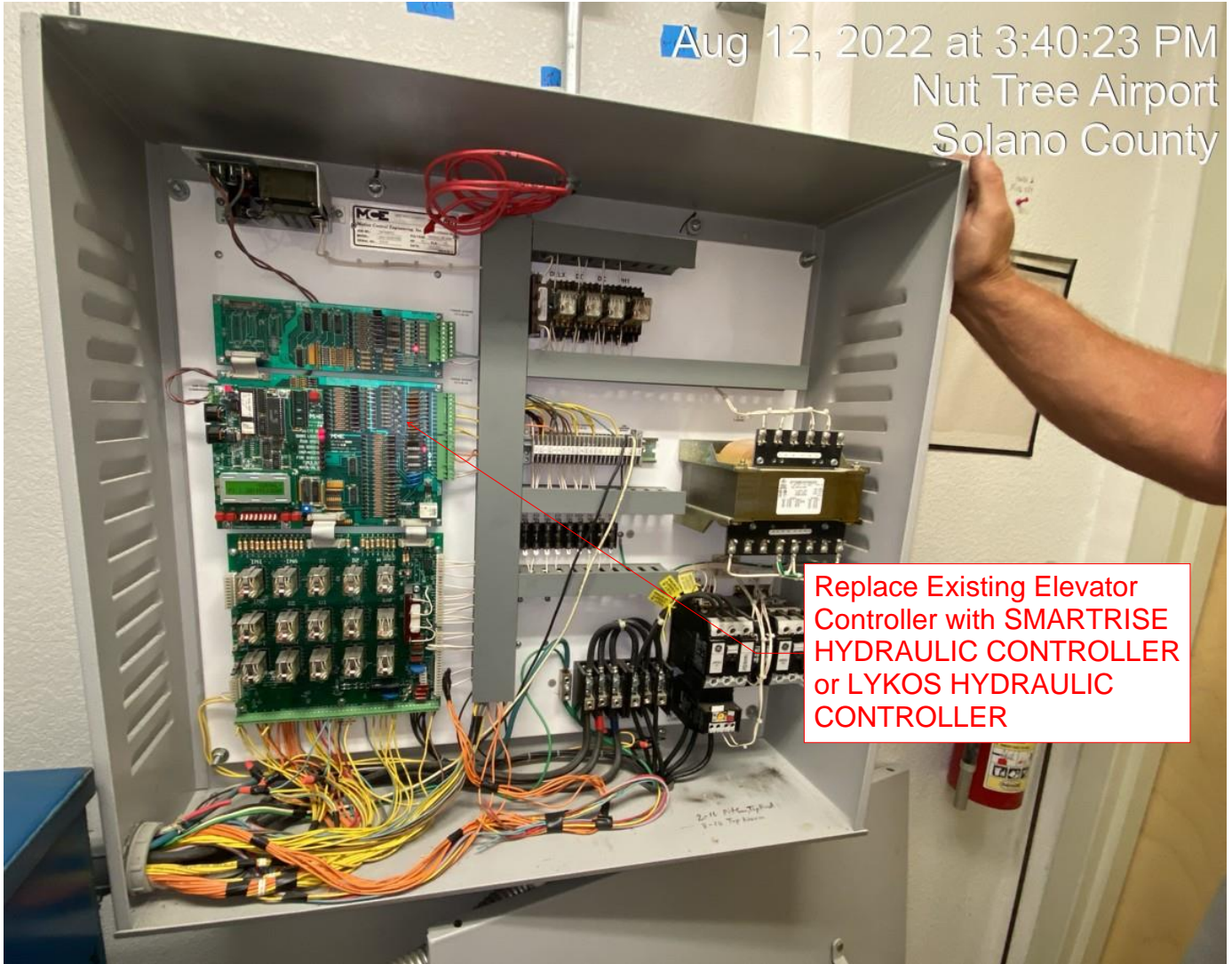



# SMARTISE HYDRAULIC CONTROLLER

# ELEVATOR CONTROLLER



# HYDRAULIC CONTROLLER

One of the only hydraulic controllers on the market with velocity and distance feedback along serial communications. Reduces valve adjustment time by showing the car's performance on the LCD display.

APPLICATION	Supports overhead, basement, and machine room-less
FEEDBACK	Distance and velocity
DISPATCH	Up to 8 car group
MAX. OPENINGS	10
MAX. SPEED	200FPM
DIMENSIONS	34"H x 24"W x 10"D
CABINET	NEMA 1, 4, 4x, and 7

## Optional Accessories

- Remote and Local Monitoring
- SmartConnect Pre-wired Inspection Box
- Isolation Transformer
- Load-Weighing Device
- Emergency Rescue Device
- Voice Annunciator
- Card Reader Access
- Traveler and Hatch Cables
- OSHPD Certified
- Air Conditioning Unit

Replacement parts available through Smartrise and other vendors.



SMARTRISE

**Phone:** 469-678-8000

**Address:** 1235 N. Union Bower Rd.  
Irving, TX 75061

**Website:** SMARTRISE.US





# BUILT STRONG

## SMART SERIAL NETWORK



**Car Top  
Controllers**

The **Car Top Controller** manages part of the safety logic. It connects to the top of the car components and the Traveler Cable.

**APPLICATION:** Localized control on top of car with full diagnostic and adjustment capabilities.

**COMPUTER:** SRU Dual Microprocessor  
**DIMENSIONS:** 18" H x 12" W  
**LOCATION:** Top of Car



**Group  
Controllers**

The **Group Controller** operates a Smart Hall Call ETA-based logic. All cars connect back to the group.

**APPLICATION:** Coordinated dispatching of multiple cars. Traction and Hydraulic from a 2 to an 8 car group.

**COMPUTER:** SRU Dual Microprocessor  
**DIMENSIONS:** 18" H x 12" W  
**LOCATION:** Machine Room



**COP  
Controllers**

Our **Car Operating Panel Controller (COP)** gathers COP localized I/O's and connects to the Car Top Controller.

**APPLICATION:** Localized control of car station functions, as well as full diagnostic and adjustment capabilities.

**COMPUTER:** SRU Dual Microprocessor  
**DIMENSIONS:** 7" H x 6" W  
**LOCATION:** Car Operating Panel



**Hall Board**

Our **Hall Board** provides a serial connection to hall fixtures. It turns Top & Bottom Access Switches, Fire Service Switches, Hall Buttons & Lanterns, and Medical Service Switches into networked devices.

**APPLICATION:** Serial connection to hall fixtures  
**DIMENSIONS:** 2 1/2" H x 2 1/4" W

**ADDITIONAL FEATURES:**

- Call buttons and other hall devices are wired locally to a Hall Board at the floor.
- All Hall Boards connect to the machine room via a shared 4-wire network or Cat-5 network cable.

# LYKOS HYDRAULIC CONTROLLER ELEVATOR CONTROLLER



# LYKOS HYDRAULIC CONTROLLER

LEADER OF THE PACK

## BENEFITS:

- Non-Proprietary Control System
- No Special Tools Needed
- Remote Adjustment and Diagnosis Via Smartphone
- Minimal Hardware Design Requires Fewer Spare Parts
- Easy-to-Read Engineering Drawings
- Popular Features are Built-in
- Superior Technical Support







# LYKOS HYDRAULIC CONTROLLER

LEADER OF THE PACK

## BENEFITS:

- Non-Proprietary Control System
- No Special Tools Needed
- Remote Adjustment and Diagnosis Via Smartphone
- Minimal Hardware Design Requires Fewer Spare Parts
- Easy-to-Read Engineering Drawings
- Popular Features are Built-in
- Superior Technical Support



# EXHIBIT 04

CAR TOP RUN STATION

SMARTRISE SMARTCONNECT  
CAR TOP RUN STATION

or

LYKOS CAR TOP RUN STATION

or

EQUAL

# SMARTISE SMARTCONNET CAR TOP RUN STATION





SmartConnect is our Inspection Box located on the top of the car. It comes pre-wired which allows for ease of installation via a Cat-5 cable. The box has pre-drilled mounting brackets with an incandescent light bulb socket. SmartConnect seamlessly integrates with our Smartrise Traction and Hydraulic controllers.

<b>Fire Service (Buzzer &amp; Jewel)</b>	Fire Service 24-28 VDC
<b>Top-Mounted Alarm Bell</b>	Bell 6VDC
<b>Dimensions</b>	12"L x 4.1"H x 6"D
<b>Enclosure Rating</b>	NEMA 1
<b>Ceramic Incandescent Light Bulb Socket</b>	
<b>3-Prong Electrical Cord Duplex Outlet GFCI, 15A 125 VAC</b>	
<b>Pre-Drilled Mounting Holes</b>	
<b>0.3 Inch Diameter Plastic Service Lamp Guard</b>	

**OPTIONAL FEATURES**

- Metal Service Lamp Guard
- Pushbutton and Switch Safety Guards
- Permanently-Attached Work Light\*
- Enclosure Rating: NEMA 4, 4x, 7, 12

\* Permanently-attached work light with GFCI, lamp, and strain relief. Standard cord length is 12 feet. Other lengths can be ordered.

**SMARTRISE.US** | 2601 Fair Oaks Boulevard  
 916.457.5129 | Sacramento, CA 95864

**SMARTRISE** 

# LYKOS

# CAR TOP RUN STATION

## SPECIFICATIONS:

<b>Dimensions</b>	30"W x 35"H x 10"D
<b>Speed</b>	Up to 200 FPM
<b>Group</b>	Up to 8 Car Group
<b>Volts</b>	208-600 VAC
<b>Landings</b>	10 Landings / 20 Openings
<b>Environment</b>	32 F - 104 F Up to 90% Non-Condensing Humidity
<b>Code</b>	ASME A17.1 & ASME A17.5 NY Appendix K, Miami
<b>Certification</b>	

## STANDARD FEATURES:

- Serial Communication via Can Bus
- Absolute Position Landing System
- Built-in LCD Screen for Diagnosis, and Adjustments
- Bluetooth Connectivity with Our Alpha+ App
- Built-in Enclosure Fan/Light
- NEMA 1 Enclosure
- Security Interface Ready
- Battery Lowering Ready
- Remote Monitoring Ready
- Solid State Starter

## OPTIONAL FEATURES:

- Traveling Cable / Hoistway Cable
- Battery Lowering Device (R&R)
- GFCI Outlet in Machine Room Enclosure
- Manual or Freight Door Interface
- Security / Card Reader Interface
- EMT / Hospital Service
- Remote Monitoring (Alpha Watch Dog)
- Emergency Power Interface
- Pre-Wired Inspection Box
- NEMA 12, 4, and 4X Available for Harsh Environments



Car Top with Pre-Wired Inspection Box



© sales@alphaelevatorcontrol.com  
 1-916-957-6900

www.alphaelevatorcontrol.com  
 6711 power inn Rd Suite B  
 Sacramento CA, 95828

# EXHIBIT 05

LANDING SYSTEM

SMARTRISE SMARTPOSITIONING

LANDING SYSTEM

or

ALPHA LANDING SYSTEM

or

EQUAL

# SMARTISE SMARTPOSITIONING LANDING SYSTEM



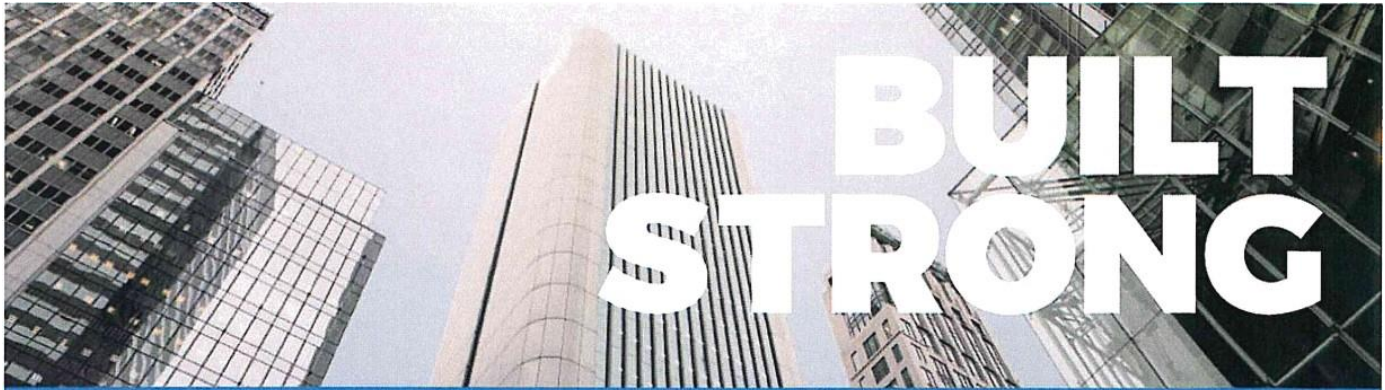

# BUILT STRONG

## SMARTPOSITIONING

Extremely safe and robust

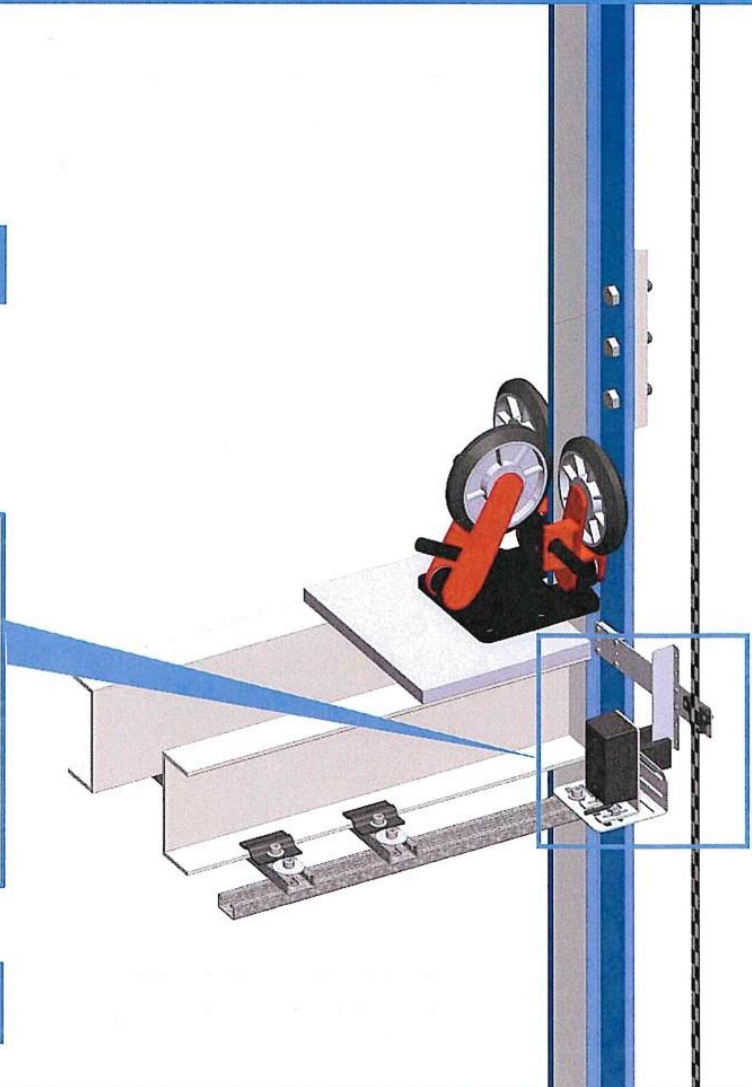
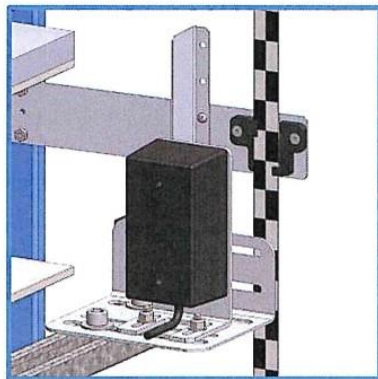

You NEED SmartPositioning

- A touchless device for **exact + consistent** elevator positioning
- Designed to meet **Code** for **required** absolute position
- Simplified to **reduce** your setup **time**
  
- **Triple redundancy floor stop**
- **Safety integrity certified**
- **Operates under extreme smoke/dust/temperature**

Watch SmartPositioning at  
[smartrise.us/training-videos](https://smartrise.us/training-videos)



# ALPHA

# LANDING SYSTEM

Revision 0.4



**ALPHA ELEVATOR CONTROLLER, INC**  
**6711 POWER INN RD, SUITE B**  
**SACRAMENTO, CA 95828**  
**TEL: (916) 957-5900**

## KUBLER LANDING SYSTEM INSTALLATION

### What's Included:

- **Top Rail Assembly:**
  - 1x Rail Fastening Plate
  - 2x Clamping Plate
  - 2x Hexagon Head Screw (YL 8.8)
  - 2x Large Diameter Washer
  - 2x Retaining Ring
  - 2x Hexagon Nut (S 1101)
  - 1x Carabiner
- **Tape Break Switch Assembly**
  - 1x Tape Break Switch Rail Fastening Plate
  - 2x Clamping Plate
  - 2x Hexagon Head Screw (YL 8.8)
  - 2x Large Diameter Washer
  - 2x Retaining Ring
  - 2x Hexagon Nut (S 1101)
  - 2x Wire Rope Cable Clamp
  - 1x Pre-Cut 1/16th in. Galvanized Vinyl Coated Steel Wire Rope
  - 1x Tape Break Switch
  - 1x Tape Break Switch Key
  - 2x TBS Long Screw
  - 2x TBS Long Screw Washer
  - 2x TBS Long Screw Nut
- **Bottom Rail Assembly:**
  - 1x Rail Fastening Plate
  - 2x Clamping Plate
  - 2x Hexagon Head Screw (YL 8.8)
  - 2x Large Diameter Washer
  - 2x Retaining Ring
  - 2x Hexagon Nut (S 1101)
  - 2x Carabiner
  - 1x Tension Spring
- **Sensor Assembly**
  - 1x Sensor
  - 1x Sensor Mounting Plate
  - 1x Sensor Fastening Screw
  - 1x Sensor Fastening Washer
  - 3x 2ft Slotted Unistrut
  - 6x Crosshead Hexagon Head Screw (307A JH)
  - 14x Crosshead Hexagon Washer
  - 6x Retaining Ring
  - 6x Hexagon Nut (S 1101)
  - 2x Sensor Plate Screw (307A JG)
  - 2x Sensor Plate Washer (Small)
  - 2x Sensor Plate Nut (LWFC)
  - 1x Coded Stainless-Steel Tape

Installation:

1. Assemble both Rail Fastening Plates using: 4x Hexagon Head Screws, 4x Hexagon Nuts, 4x Large Diameter Washers, 4x Retaining Rings and 4x Clamping Plates loosely. Each rail fastening plate will use 2 of each item listed above. See Figure 1



Figure 1: Assembled Rail Fastening Plate

2. Attach one of the assembled Rail Fastening Plates to the top of the guide rail in the hoistway overhead. Fastening plate may be oriented on either side of the guide rail. See Figure 2

Left Side Orientation

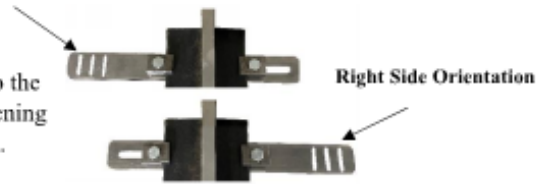

Right Side Orientation

Figure 2: Top Rail Fastening Plate Installation

3. Attach the Coded Stainless-Steel Tape to the Rail Fastening Plate.
  - a. Loop a Carabiner through a round hole close to the top of the tape.
  - b. Attach the Carabiner and tape to the Rail Fastening Plate by putting the Carabiner through the outermost slot if possible.
    - i. If using a different slot, make note of which slot the carabiner is on; the same slot will be used when installing the tape on the bottom rail fastening plate.
  - c. Ensure the tape is correctly oriented with the square holes on the right side of the tape. See Figure 3
4. Move the car down on inspection, unrolling the Coded Stainless-Steel Tape as you go. When you reach the bottom, drop the remaining tape into the pit.
5. In the pit, install the other assembled Rail Fastening Plate near the bottom of the guide rail following the same orientation as in step 2.

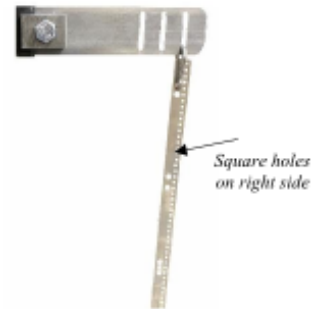

Figure 3: Top Rail Fastening Plate with Carabiner and Tape

6. Connect one Carabiner to the top of the Tension Spring and one to the bottom of the tension spring.
7. Connect the spring's top carabiner to a round hole on the tape. This will be where the tape ends.
  - a. Choose a hole such that the distance between the bottom of the spring's bottom carabiner and the top of the Rail Fastening Plate is between 2.0 – 3.0 inches when the spring is hanging and unstretched. See Figure 4
8. Connect the spring's bottom carabiner to the bottom Rail Fastening Plate using the same slot that was used at the top of the hoistway from step 3.

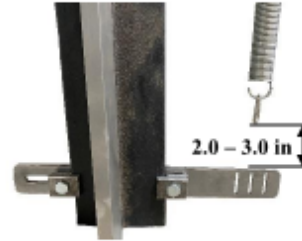

Figure 4: Distance from Bottom Carabiner of Tension Spring to Top of the Rail Fastening Plate

9. Cut the tape between ~0.2 – 0.6 inches down from the center of the hole that the bottom carabiner will go through. See Figure 5



Figure 5: Excess Tape Cutoff

10. Install the Tape Break Switch Fastening Plate to the guide rail 2 – 3 feet above the bottom Rail Fastening Plate.
11. Connect the tape break switch to the plate with the key pointing downward; the key location can be adjusted on the tape break switch. The tape break switch must be parallel to the tape with some distance between. See Figure 6



Figure 6: Tape Break Switch

12. Connect the supplied wire rope, from the pull tab key to the top of the tension spring using the supplied wire clamp. Leave some slack to allow key to be pulled. See Figure 7
  - a. The key will be connected to one side of the wire rope with a wire clamp on it already.
  - b. Thread the other side of the wire rope, through the side of the upper hook that is enclosed by the carabiner, and a wire clamp to make a loop and tighten both nuts as tight as possible. Cut any excess wire rope. If the tape breaks, the spring will retract and pull down the key.

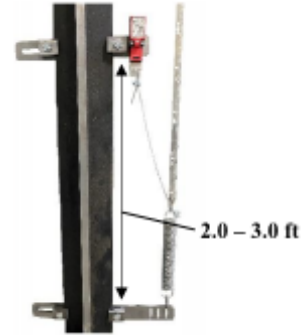

Figure 7: Tape Break Switch Assembly

13. Bring a pair of hoistway wires to connect the safety string circuit from the safety board to the tape break switch. See Figure 8 for safety board connection.

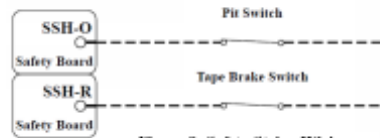

Figure 8: Safety String Wiring

14. Unscrew and remove the front cover of the tape break switch to connect the normally closed contact to the safety string circuit through the hole. Ensure the contact is closed when the key is inserted and open when the key is removed. Close the cover and tighten screw after. See Figure 9



Figure 9: Tape Break Switch Contacts

15. Install the Sensor Mounting Plate to the crosshead on top of the car, using the supplied unistruts, washers and screws. Make sure to align the sensor mounting plate with the tape as much as possible. See Figure 10



Figure 10: Sensor Mounting Plate Crosshead Installation

16. Install the Sensor to the Sensor Mounting Plate using the Sensor Fastening Screw and the Sensor Fastening Washer but do not fully tighten the screw to allow for adjustments. The sensor will need to be oriented accordingly with the tape (use sticker on sensor for reference). See Figure 11



Figure 11: Sensor and Plate Assembly

17. Remove the outer sliding strip from the sensor by loosening the sliding strip lock screw on the sliding strip lock and either pulling back the lock or sliding it to the side. Figure 12

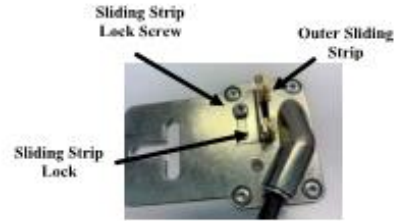

Figure 12: Sliding Strip Lock

18. Slide the tape in through the side of the sensor and insert the sliding strip back into the sensor by aligning the side of the strip with the tape. Fully tighten the sliding strip lock after. See Figure 13



Figure 13: Sensor and Tape Installation

19. Adjust the sensor's position using the T-hole so that the tape is straight and not tilted to the side. Once the tape is correctly positioned in the sensor, fully tighten the Sensor Fastening Screw. See Figure 14

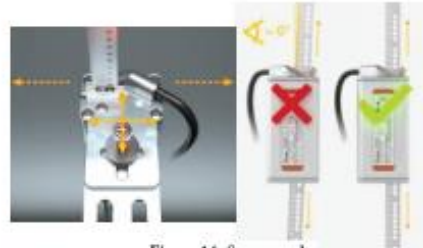

Figure 14: Sensor and Tape Alignment

20. Connect the 4 wires of the sensor for power and communication to the cartop UI board. See Figure 15

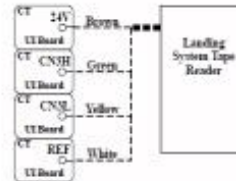

Figure 15: Sensor Wire Connections



# EXHIBIT 06

## CAR AND HALL FIXTURES

REPLACE EXISTING ELEVATOR CAR AND HALL FIXTURE



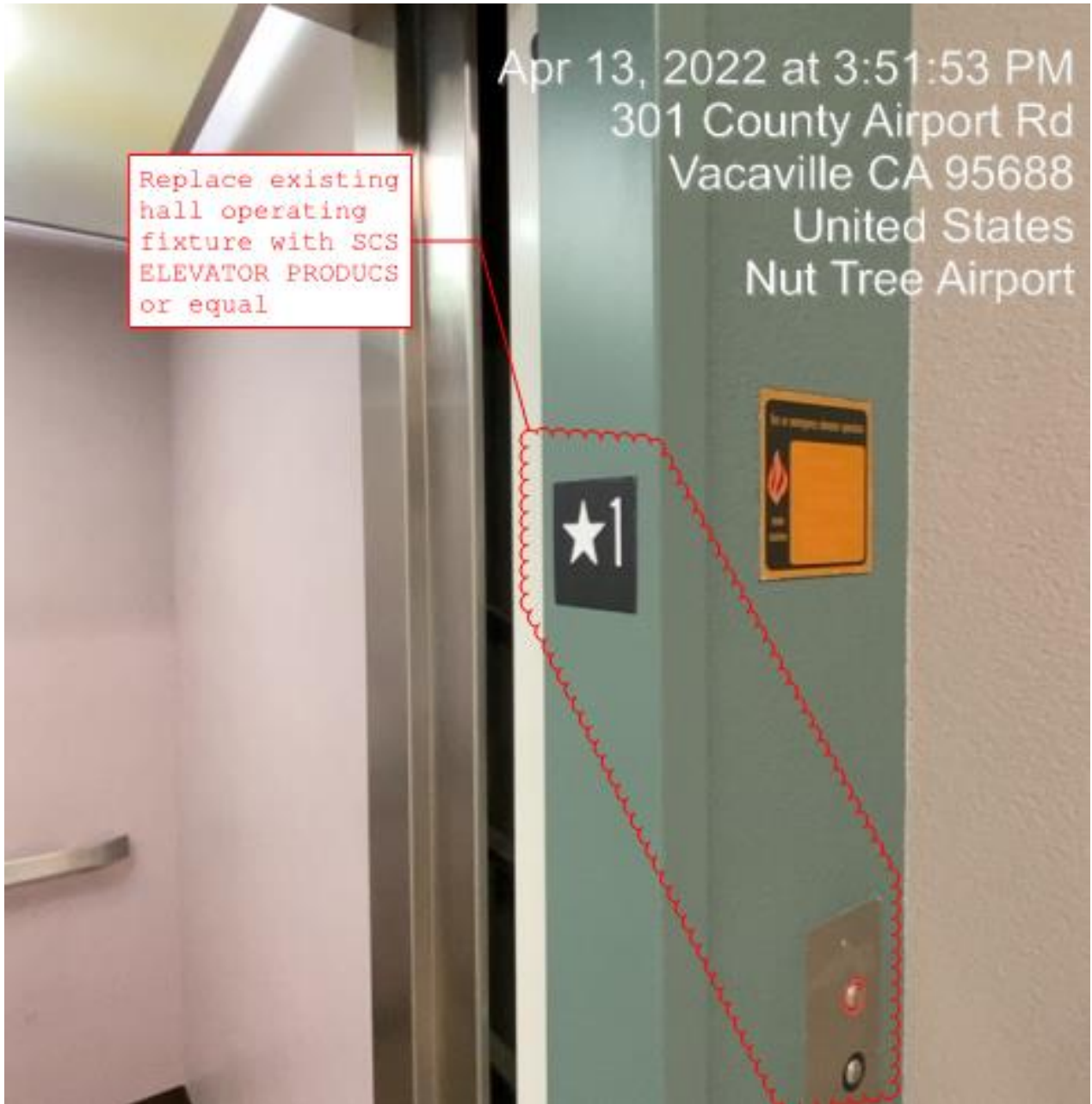

















(800) 783-4633

CAB BRAILLE - CAST/RESIN

WWW.SCELEVATORPRODUCTS.COM



<b>DIE CAST METAL</b>	
<b>CW1</b> (FITS DIE CAST CW2 BRAILLE)	
<b>Part Size</b>	2.750" x 1.500" (± .010")
<b>Thickness</b>	0.125"
<b>Diameter Opening</b>	1.528"
<b>Mounting</b>	Surface or Flush (with flanges)
<b>Finishes</b>	Satin Nickel, Satin Bronze, Mirrored Stainless or Mirrored Bronze. Painted: Black, Nickel or Goldleaf.



<b>RESIN</b>	
<b>2010056</b> FITS WITH CCU1 AND RCU1	
<b>Part Size</b>	3.480" x 1.700"
<b>Thickness</b>	0.130"
<b>Diameter Opening</b>	1.366" (designed to fit 1.350" button body)
<b>Mounting</b>	Studless (uses studs from braille & threaded body of bottom)
<b>Finishes</b>	Satin Tri-Chrome - 2010056 Black - 2010057 Mirrored Chrome - 2010091 PVD Mirrored Bronze - 2010141



<b>DIE CAST METAL</b>	
<b>CW11190</b> (FITS DIE CAST CW2 BRAILLE)	
<b>Part Size</b>	2.906" x 1.66"
<b>Thickness</b>	0.115"
<b>Diameter Opening</b>	1.190"
<b>Mounting</b>	Studless (uses studs from braille & threaded body of button)



<b>DIE CAST METAL</b>	
<b>CCU1</b> - ANSI COMPLIANT	
<b>Part Size</b>	1.955" x 1.358" (± .010")
<b>Thickness</b>	0.070"



<b>DIE CAST METAL</b>	
<b>CW2</b> - ANSI COMPLIANT	
<b>Part Size</b>	1.560" x 1.358" (± .010")
<b>Thickness</b>	0.053"



<b>RESIN</b>	
<b>RCU1</b> - ANSI COMPLIANT	
<b>Part Size</b>	1.955" x 1.358" (± .010")
<b>Thickness</b>	0.070"
<b>Designation Color</b>	White
<b>Background Color</b>	Black

<b>STANDARD SPECS</b> (unless otherwise noted)	
<b>Designation Color</b>	Satin Nickel, Satin Bronze, Mirrored Stainless or Mirrored Bronze. Painted: White, Black, Nickel, Goldleaf or US26.
<b>Background Color</b>	Painted
<b>Character Height</b>	0.625"
<b>Standard Font</b>	Helvetica Medium
<b>Mounting</b>	Standard with Studs, Adhesive Available Upon Request or Back Flange Mounting



(800) 783-4633

JAMB BRAILLE - CAST

WWW.SCELEVATORPRODUCTS.COM



**JENNIFER MATZEK**

Teaming up with our customers to assure they receive the parts they require and have the best customer service experience possible.

SALES TEAM MEMBER/DATA ENTRY



**DIE CAST METAL**  
**CJT24 ANSI COMPLIANT**

<b>Part Size</b>	2.5" x 3.5" (± .010")
<b>Thickness</b>	0.090"
<b>Character Height</b>	2.000"
<b>Corner Radius</b>	0.125"

**DIE CAST METAL**  
**CJ3**

<b>Part Size</b>	3.00" x 4.00" (± .010")
<b>Thickness</b>	0.090"
<b>Corner Radius</b>	0.031"



**DIE CAST METAL**  
**LCJ229**

<b>Part Size</b>	2.500" x 4.000" (± .010")
<b>Thickness</b>	0.080"
<b>Character Height</b>	0.400" Title / 3.000" Designation
<b>Corner Radius</b>	0.125"

**RESIN**  
**RJ4**

<b>Part Size</b>	4.000" x 4.000" (± .010")
<b>Thickness</b>	0.080
<b>Corner Radius</b>	0.0625"
<b>Designation Color</b>	White
<b>Background Color</b>	Black
<b>Mounting</b>	Adhesive

**STANDARD SPECS** (unless otherwise noted)

<b>Designation Color</b>	Satin Nickel, Satin Bronze, Mirrored Stainless or Mirrored Bronze. Painted: White, Black, Nickel or Goldleaf.
<b>Background Color</b>	Painted
<b>Standard Font</b>	Helvetica Medium
<b>Mounting</b>	Standard with Studs, Adhesive Available Upon Request or Back Flange Mounting

(800) 783-4633

THE PAVE SERIES BUTTONS

WWW.SCSELEVATORPRODUCTS.COM

# The **PAVE** Series

## Protection Against Vandalizing Elevators

Discover our newly redesigned vandal prevention buttons. With 2 body styles and sizes, 3 finish options and 12 target styles available to choose from, our latest PAVE Button is the most versatile that we have ever offered.

**Design your own button using numerous combinations available**



FINISH CODE	FINISH CODE DESCRIPTION
SS	Stainless Steel
SB	Satin Bronze (PVD Coated)
BK	Black (PVD Coated)

### PAVE Series Target Style







Projecting					
Illuminating	Indicator				
	Flat	Concave	Flat	Concave	Concave
PFIL	PCOO	PF00	PF10	PC10	PC1R
CA COMPLIANT					
SS					
SB					









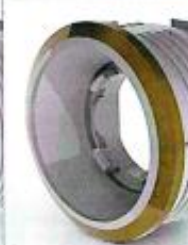





*Protect your Elevator*  
**ORDER THE LATEST IN VANDAL PREVENTION**



**PAVE** Series Button Body Styles and Sizes

1.35" No Halo <b>P350</b>	1.35" Halo <b>P35H</b>	1.26" No Halo <b>P260</b>	1.26" Halo <b>P26H</b>
 SS			
 SB			

Rings		Flush				Rings	
		Indicator					
Flat <b>PFIR</b>	Flat <b>PFRO</b>	Domed <b>FD00</b>	Domed <b>FD10</b>	Domed <b>FDIR</b>	Domed <b>FDRO</b>		
							
							



(800) 783-4633

CONTACT BASES

WWW.SCELEVATORPRODUCTS.COM

CONTACT BASES

**MULTI-VOLT (3LED) 24 to 120 VOLT**



2010018 - CB3B  
Blue LED



2010014 - CB3R  
Red LED



2010020 - CB3G  
Green LED

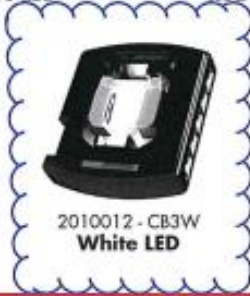

2010012 - CB3W  
White LED



2010015 - CB3A  
Amber LED

CONTACT BASES

**MULTI-VOLT (1LED) 6 to 120 VOLT**



2009262 - CB1B  
Blue LED



2009260 - CB1R  
Red LED



2009263 - CB1G  
Green LED



2009259 - CB1W  
White LED



2009261 - CB1A  
Amber LED



2009258 - CBO  
No LED

CONTACT BASES

**LOW-VOLT (1LED) 2-VOLT**



2012026 - CB1R-LV  
Red LED



# DOCUMENTATION 2 - SITE UTILIZATION PLAN



**Preliminary**



# Preliminary

## DOCUMENTATION 2 - SITE UTILIZATION PLAN

— Contractor Access

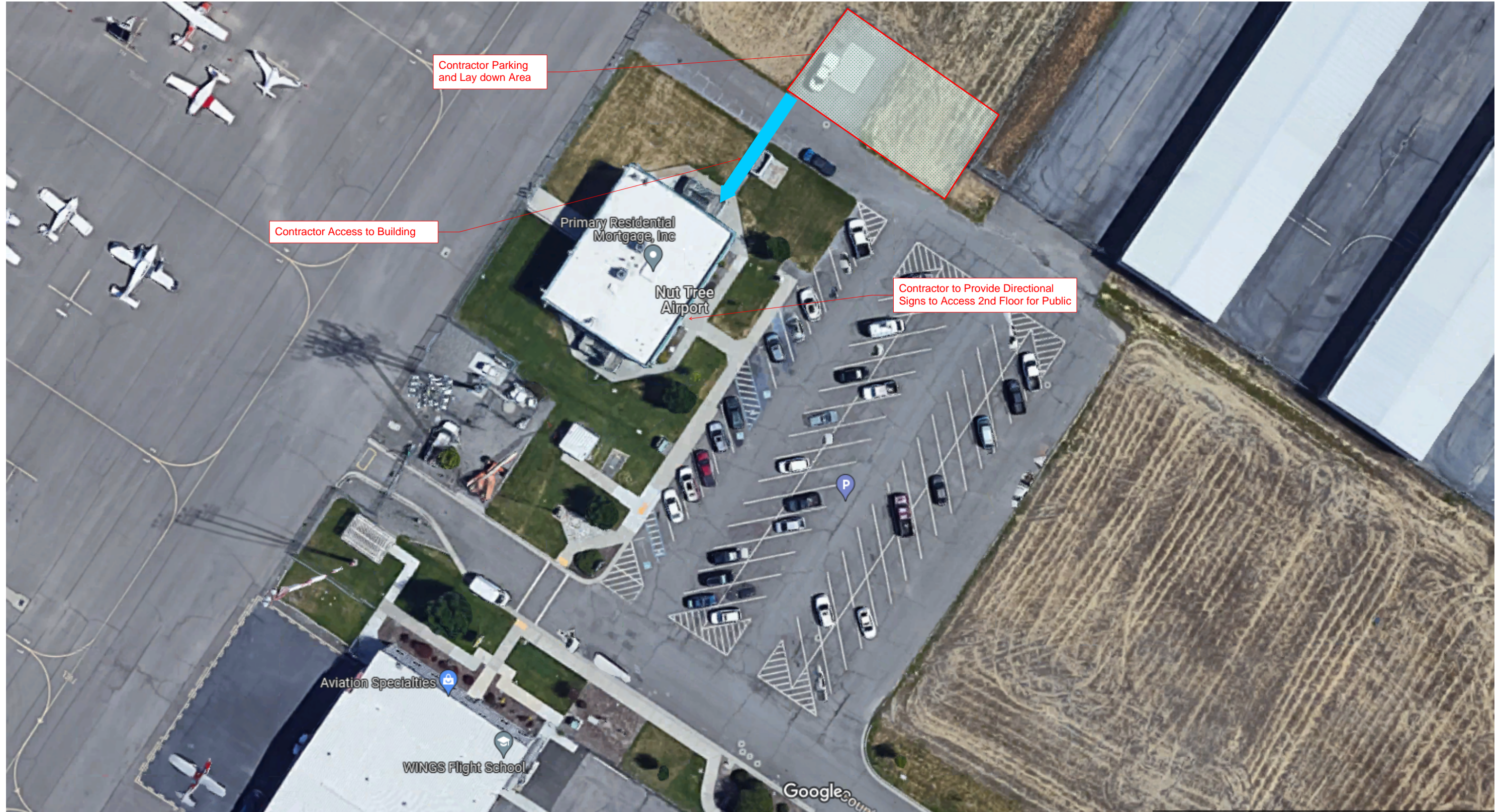



# Preliminary

 Contractor Access

Elevator Room & Contractor Storage Area During Construction

Elevator

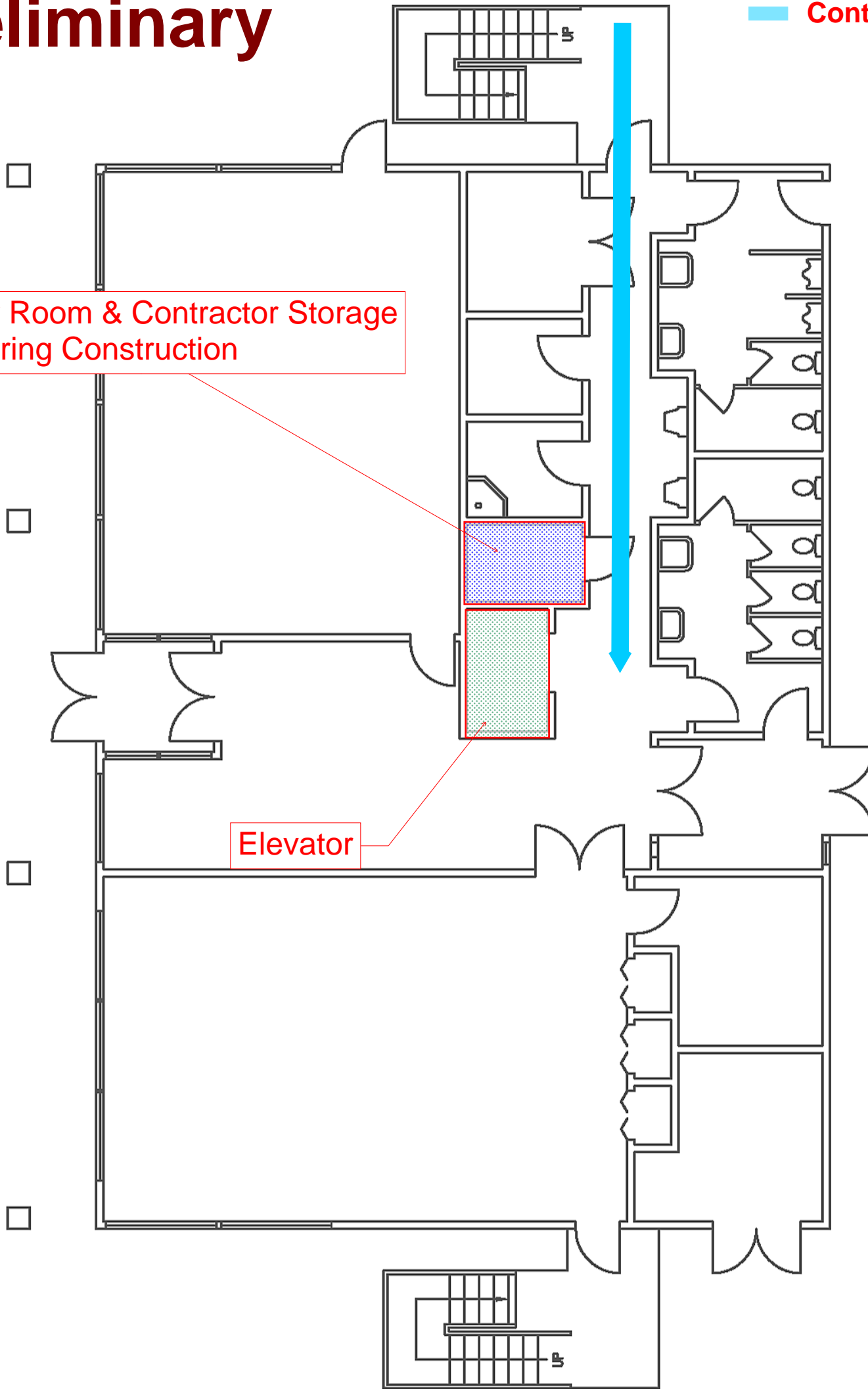

301 COUNTRY ROAD – FIRST FLOOR PLAN

NOT TO SCALE



# Preliminary

Public Access

## DOCUMENTATION 2 - SITE UTILIZATION PLAN

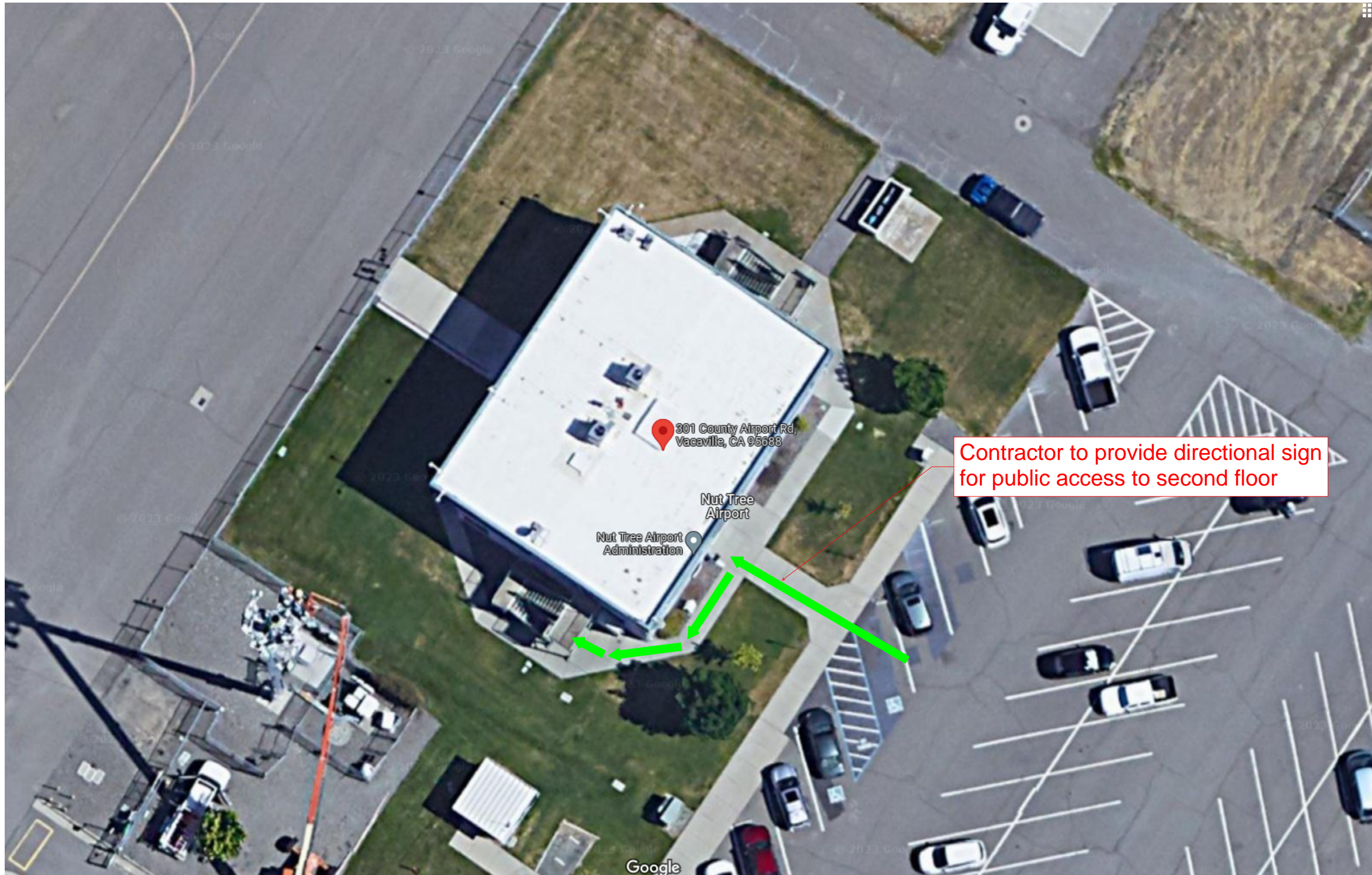



# Preliminary

Public Access

Contractor to provide directional sign for public access to second floor

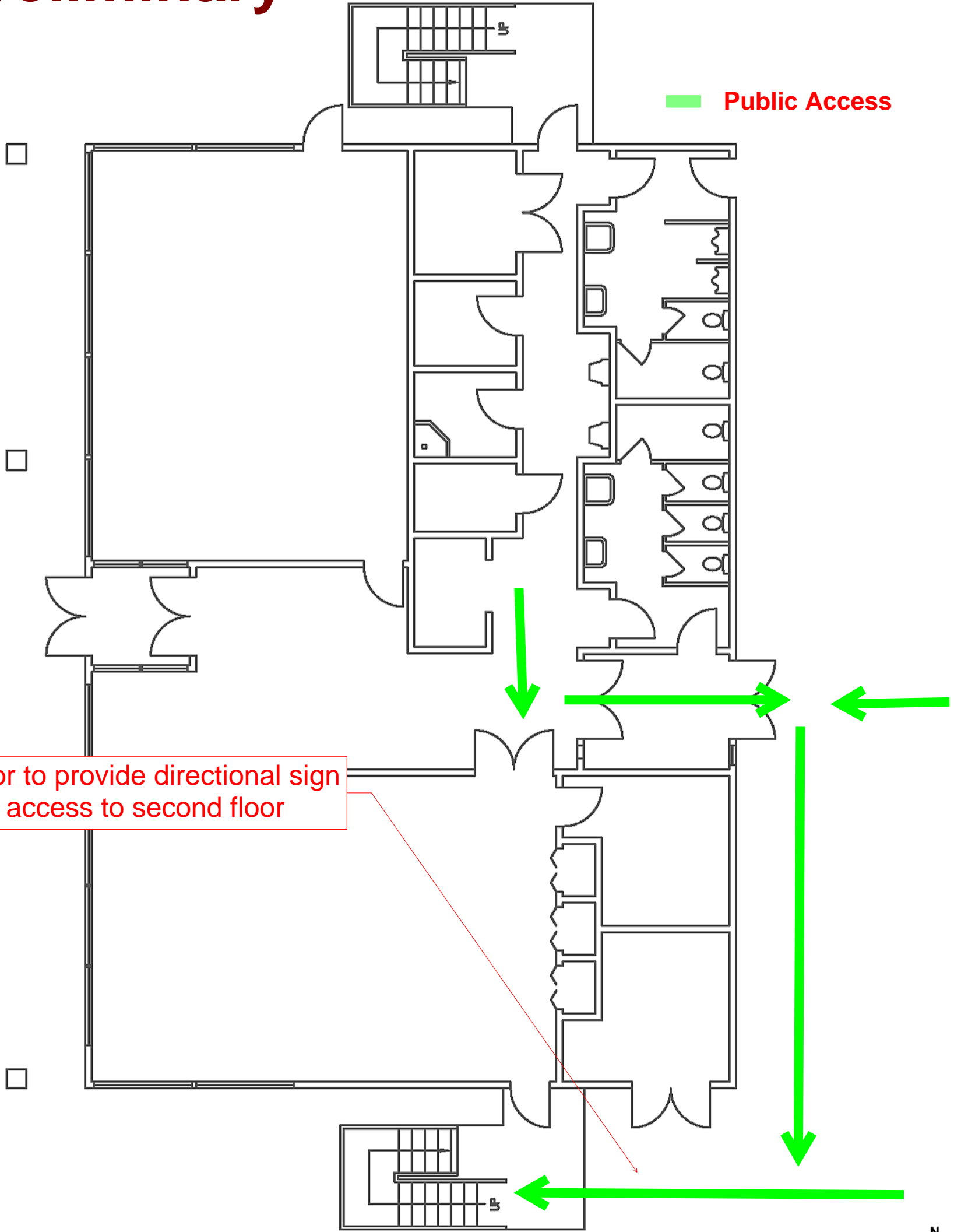

301 COUNTRY ROAD – FIRST FLOOR PLAN

NOT TO SCALE



# Preliminary

 **Public Access**

ADA Special Needs Room  
for Public if they can't use  
stairs

Contractor to provide directional  
sign for public for special needs  
that can't use stairs

Call Molly at 707-469-4600 for ADA  
Special Needs



301 COUNTRY ROAD – FIRST FLOOR PLAN

NOT TO SCALE

**SECOND FLOOR ELEVATOR  
NON OPERATIONAL DURING  
CONSTRUCTION**

**Public Access**

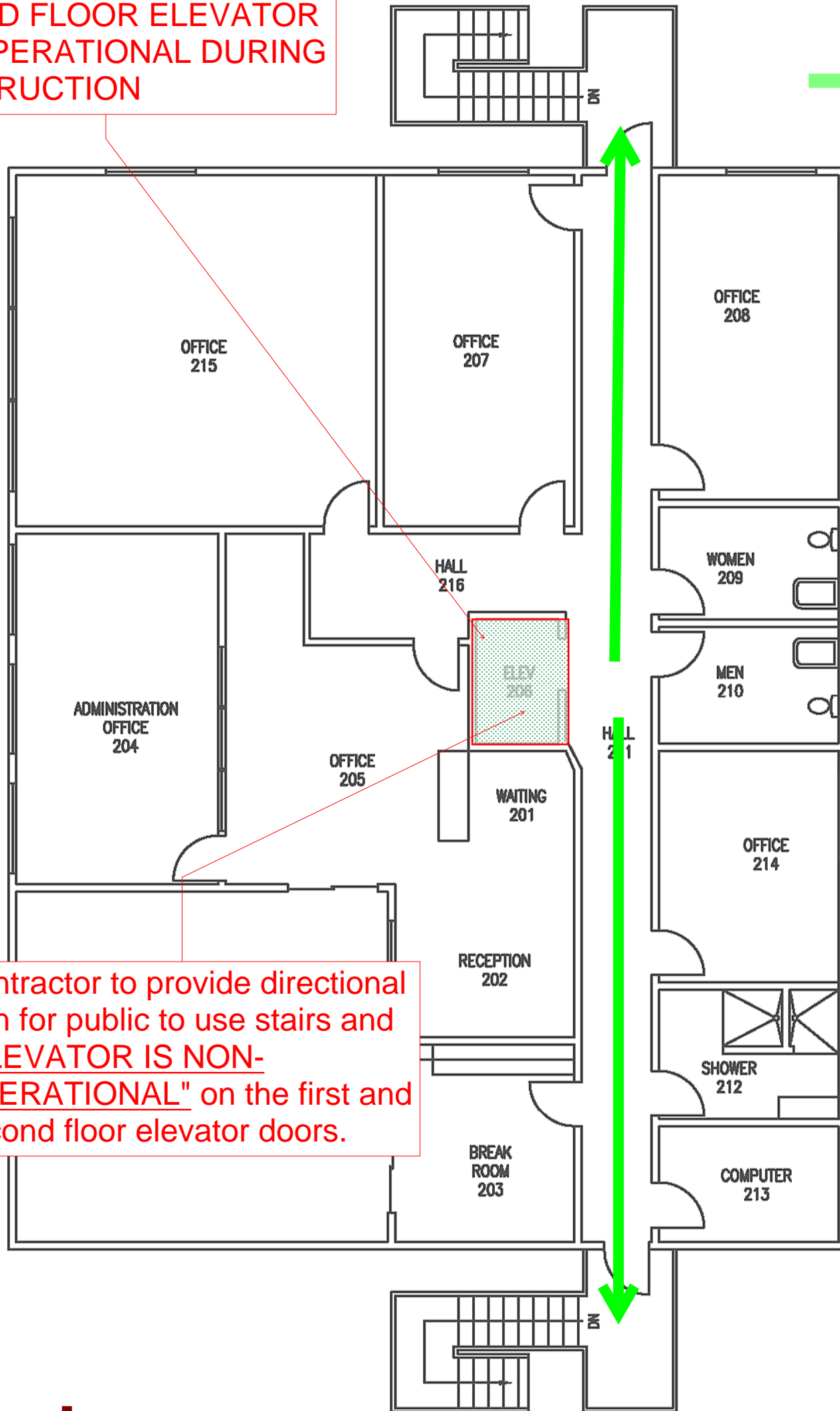

**Contractor to provide directional  
sign for public to use stairs and  
"ELEVATOR IS NON-  
OPERATIONAL" on the first and  
second floor elevator doors.**

**Preliminary**



301 COUNTRY ROAD – SECOND FLOOR PLAN

NOT TO SCALE

**CONTRACTOR TO PROVIDE DIRECTIONAL SIGNS**

**A-Frame Directional Signs**

